

# A Robust Vision System Against the Change of Lighting Condition

Keiichi Yamada \* Morimichi Mizuno Toshihiko Tsukada Shin Yamamoto  
Toyota Central Research and Development Laboratories, Inc.

## Abstract

This paper presents a robust vision system for lighting fluctuation for a parts positioning robot by means of dynamic range expansion of a video camera. The vision system was confirmed by experiments to stably detect the position of the object, in comparison to a conventional method, even if the light environment dynamically varies. The above result revealed that the dynamic range expansion of a video camera is very effective for realizing a robust vision system against the fluctuation of a light environment.

## 1 Introduction

Today, many robot vision systems are put into practical use in the industry field. However, the insufficient robustness against the change of environments, especially the change of lighting condition, is an important and practical problem for many of the robot vision systems. Because of the problem, a lot of costs should be paid for arranging the lighting condition and tuning the algorithm of the vision system.

The reason why the vision system has such a low tolerance to the fluctuation of the illumination condition is considered in next two points. First, the image processing algorithm is not robust for the change of the illumination condition. Second, the dynamic range of a video camera is insufficient, and that causes the lack in information in the images under various lighting condition. The dynamic range insufficiency leads to the insufficient robustness of the vision system even if a robust processing algorithm is employed.

While many works on the robust processing algorithm have been reported [1, 2, 3, 4], these technologies cannot make up the lacking in information in the image sensing stage due to the dynamic range shortage of the video camera. Consequently, not only improvement on the algorithm of the image processing but also prevention of the failure of information in the imaging stage by expanding the dynamic range is considered to be indispensable to solve the mentioned problems.

Several researches pointed out the insufficiency of the dynamic range of video cameras, and also re-

ported methods for expanding the dynamic range [5, 6, 7]. However, no research reported quantitatively about the effectiveness of the dynamic range expansion of the video camera for the improvement on the robustness of the vision systems for the industry application.

There exist two kinds of approaches for expanding the dynamic range of a video camera. One is by improving the characteristic of image sensor elements, and the other is by synthesizing the image having an expanded dynamic range from multiple images captured under different exposure conditions with conventional image sensor elements. As the former, some logarithmic conversion CCD image sensors have been developed [7]. However, the number of picture elements is insufficient to apply to the robot vision system. In the meantime, by the latter method, we have developed a wide dynamic range vision sensor by synthesis of the multiple images in previous work [8].

The purpose of our research is to develop a robust robot vision system which stably operates for the illumination fluctuation in the factory environment. As a means for realizing this, the dynamic range of the video camera which inputs the image into the vision system is expanded to be capable of sensing the images without lack of information even if the light environment dynamically varies. This paper reports the robot vision system we have developed and its robustness for the fluctuation of a light environment. Then, it reveals that the dynamic range expansion of the video camera is very effective for realizing the robot vision system which operates robustly to the fluctuation of the light environment.

## 2 Method for expanding dynamic range

By combining  $n$  images, each of which is captured with different exposure time, into an image, an image with a dynamic range of  $\alpha^{n-1}$  times as wide as that of the video camera itself can be obtained [8]. Where,  $\alpha$  is a ratio of two exposure times.

Suppose two kinds of exposure time  $T_1$ , and  $T_2$  ( $T_2 > T_1$ ). The combination of the two images is carried out for each pixel, as shown in Fig. 1. If the pixel value  $L_2$  of the image for the longer exposure time  $T_2$  is not saturated, the pixel value  $L_2$  is adopted as a pixel value of the synthesis image. Else, the pixel value  $L_1$  for the shorter exposure time

\*Address: Nagakute-cho, Aichi-gun, Aichi-ken, 480-11 Japan. E-mail: yamakei@cov.tytlabs.co.jp

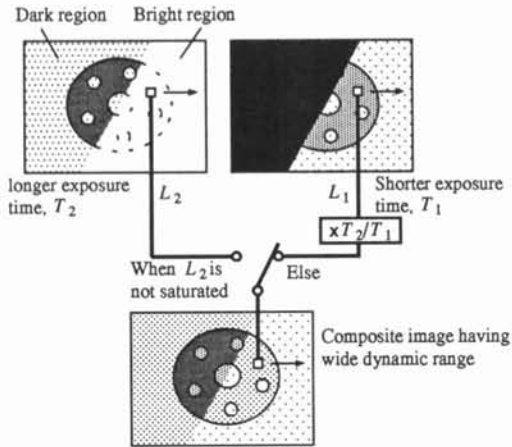

Figure 1: Method for expanding dynamic range.

$T_1$  is adopted as that. When the pixel value  $L_1$  is adopted, the value is multiplied by the ratio in two exposures time  $T_2/T_1$  to unify the sensitivity.

The process described above obtains an image which has a wide dynamic range with good signal to noise ratio. Note that, when the type in the exposure time is more than three, these images are combined into one image by the recursive process of a combination of two images.

### 3 Vision system having expanded dynamic range

#### 3.1 Object and illumination condition

The vision system is for a parts assembling robot, and it performs a two-dimensional pose detection of an object on a conveyer. The object for positioning is a component of automobile engine parts and which is made by alloy aluminum cast. The image of the object is captured from above position using a reflection illumination system. The vision system is intended to determine the position of the object by detecting the round-holes of the object.

The measuring result of the illuminance of the production field in a factory showed that the variation range of the illuminance is from 500 lux to 10,000 lux. The illuminance of 10,000 lux is approximately the brightness in the illuminating by the solar light directly incoming through a window of the factory.

We aimed to develop a vision system which stably operates in the above lighting condition without arranging the lighting environment. Specifically, the lighting condition is that the variation range of an illuminance is from 500 lux to 10,000 lux, and the variation range of a lighting direction, in the above illuminance range, is from 15 degrees to 90 degrees for the plane the object is put on.

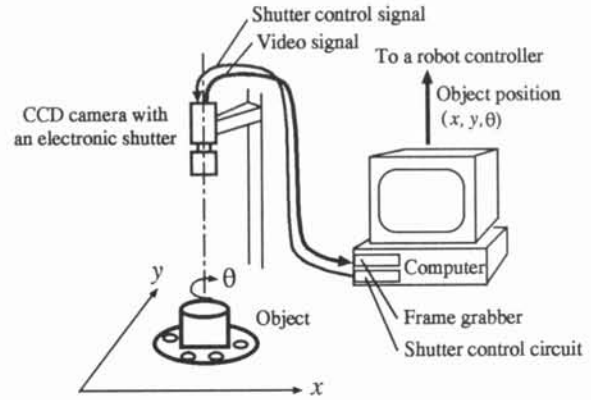

Figure 2: Developed vision system.

### 3.2 System construction

We have developed an experimental vision system for parts positioning with a video camera whose dynamic range is expanded with the above-mentioned method. Fig. 2 shows the composition of the vision system. The system is composed of a monochrome NTSC format CCD camera with electronic shutter function, a shutter control circuit, a frame grabber, a personal computer (Pentium 90MHz), and software. The software is for combining the captured images to expand the dynamic range of the CCD camera, and also for detecting the object position from the image having expanded dynamic range. By controlling the electronic shutter of the CCD camera with the shutter control circuit, two images for exposure time  $T_1$  and  $T_2$  are sequentially captured in a 1/15 seconds with the frame grabber. Then, the captured images are transferred to the computer through a PCI bus. Finally, the image having an expanded dynamic range is synthesized from these two images by the software processing.

### 3.3 Detection algorithm

In addition to the expansion of the dynamic range, detection of the object position is also executed with the identical computer by next two steps. First, the round-holes are detected from the image having an expanded the dynamic range. Second, the position of the object is determined by matching the location of the detected round-holes with the location data of the round-holes for the object.

To detect the round-holes, pattern matching according to the normalization cross correlation of the gray value between the image and a template pattern of a round-hole was used. Let the normalization cross correlation between the image  $f(i, j)$  and a template pattern  $g(u, v)$  be  $C_{fg}(i, j)$ . Then, each round-hole location  $(i, j)$  is detected by calculating the local gravity center of the normalization cross correlation  $C_{fg}(i, j)$  where the correlation value is

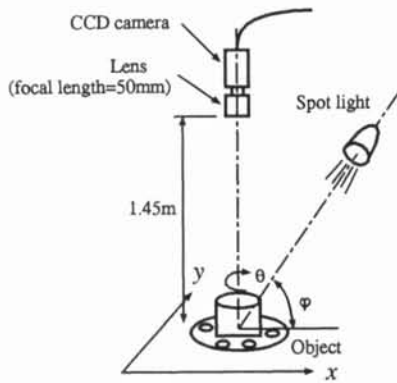

Figure 3: Experimental method.

over a threshold  $C_{th}$ . The template pattern is that inside of the round-hole contour is 0, and outside of that is 1. Therefore, the template pattern matches the contrast of the intensity at the contour of a round-hole in the target image.

## 4 Experiment

### 4.1 Experimental method

The robustness of the developed vision system for the fluctuation of the light environment was investigated. Fig. 3 shows the experimental method. In the experiment, the recognition result of round-holes and object position was examined by changing an illumination condition variously with a spot light. The recognition result was compared to the vision system which does not expand the dynamic range of the CCD camera in order to evaluate the effect of dynamic range expansion. For both of the vision systems, an identical detection algorithm was used. The exposure time  $T_1$  and  $T_2$  for the dynamic range expansion was set 1/900 seconds and 1/60 seconds.

The brightness in the laboratory where the experiment was performed was 270 lux when the object is not illuminated by the spot light. The iris of the camera lens was stop down to the limit condition the vision system can detect all of the round-holes. The lighting angle  $\varphi$  was made to change from 15 degrees to 85 degrees with respect to a horizontal plane, and in addition, the lighting strength was made to change from 500 lux to 50,000 lux in normal illuminance at each lighting angle. Because the lighting equipment hide the object in the angle more than 85 degrees, the largest lighting angle was 85 degrees in this experiment. While the object has five small round-holes and one big round-hole, the five small round-holes were intended to be detected for determining the position of the object in this experiment. The threshold  $C_{th}$  of correlation for detecting round-holes was made to be 0.65.

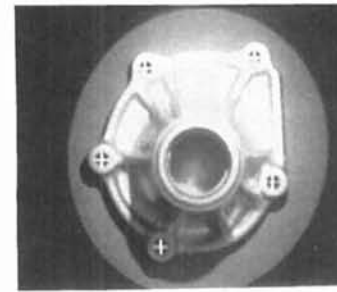

(a) expanded dynamic range

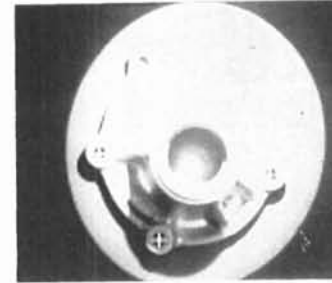

(b) conventional dynamic range

Figure 4: Examples of obtained images. Cross marks represent the location of detected round-holes.

### 4.2 Experimental results

Fig. 4 shows a couple of images obtained under the illuminance of 10,000 lux and the lighting angle of 75 degrees. In the figure, (a) is the image obtained with the vision system which expands the dynamic range, and (b) is with the vision system which does not expand the dynamic range. In these images, the area which brightens in a round shape is the region where the spot light was exposed. Also, the cross marks in these figures represent the location of the round-holes detected. As shown in the figures, the vision system which does not expand the dynamic range detected only three of the five round-holes due to saturation of the image. On the other hand, the vision system which expands the dynamic range detected all of the five round-holes.

Fig. 5 (a) and (b) show the relationship between illumination condition and recognition result of the round-holes, for each of the vision systems. In each figure, the horizontal axis shows the illuminance at the position the object was put. The vertical axis shows correct detection rate and incorrect detection rate of the round-holes. The definition of the incorrect detection rate is the ratio of the number of incorrectly detected round-holes to the number of actual round-holes the object has.

From Fig. 5 (a), the vision system which expands the dynamic range detected all of the round-holes for the lighting angle from 15 degrees to 85 degrees in an illuminance range between 270 lux and 10,000 lux, approximately 37 times the illuminance variation. On the other hand, from Fig. 5 (b), the

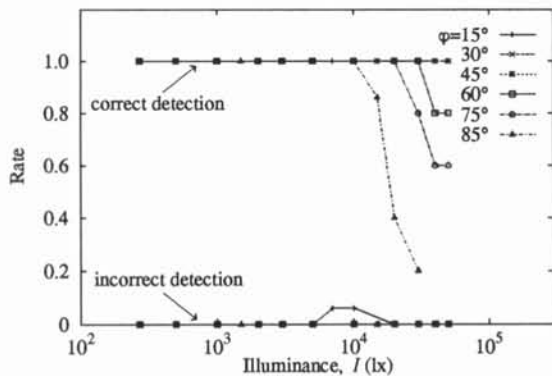

(a) expanded dynamic range

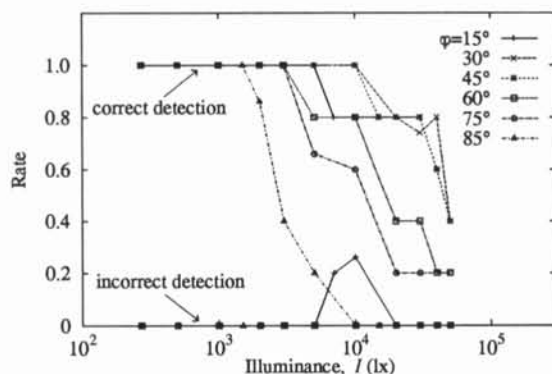

(b) conventional dynamic range

Figure 5: Experimental results; correct detection rate and incorrect detection rate of the round-holes vs. lighting condition.

vision system which does not expand the dynamic range detected all of the round-holes for an illuminance range between 270 lux and 1,500 lux, approximately 5.5 times the illuminance variation. Note that, the incorrect detection of round-holes occurred at the dark region whose shape looks like a round-hole which arose by the negative convex division of the object.

Assuming a factory environment mentioned in section 3.1, the recognition rate of the position in an illuminance range between 500 lux and 10,000 lux was calculated for the 105 images got in the experiment for each of the vision systems. As the result, the recognition rate when the dynamic range was expanded was 100 % for the 105 samples, while it was 83 % when the dynamic range was not expanded. The performance of the positioning vision system is summarized in Table 1.

The above results showed that the robust and stable vision system for the lighting fluctuation could be realized by preventing the failure of information, in the image sensing stage, by expanding the dynamic range of the CCD camera.

Table 1: Performance of the vision systems when the lighting condition changes in a range between 500 lux to 10,000 lux.

	vision system which expands dynamic range	vision system which does not expand dynamic range
Recognition rate	100 (%)	83 (%)
Position accuracy	< 1.0 (pix.)	< 1.0 (pix.)
Processing time	1.2 (s)	1.2 (s)

## 5 Conclusion

A robust vision system for the fluctuation of the light environment was developed by expanding the dynamic range of the video camera to prevent the failure of image information in the sensing stage. The dynamic range of a conventional CCD camera was expanded by combining plural images taken under different exposure condition. The vision system, including the dynamic range expansion and the object position detection, was implemented into a personal computer. The effectiveness of the developed vision system was confirmed by the experiment, and the results showed that the dynamic range expansion of the imaging stage is very effective for realizing robust robot vision systems for the fluctuation of the light environment.

## References

- [1] N. Ohtsu, "A threshold selection method from gray-level histograms," *IEEE Trans Syst., Man and Cybern.*, vol. SMC-9, no. 1, pp. 62-66, Jan. 1979.
- [2] A. Shio, "An automatic thresholding algorithm based on an illumination-independent contrast measure," *CVPR '89*, pp. 632-637, 1989.
- [3] W. M. Silver, "Normalized correlation search in alignment, gauging, and inspection," *SPIE*, vol. 755, pp.23-34, 1987.
- [4] E. Maeda, et al., "Robust object extraction using normalized component features," *ICPR '92*, vol. 3, pp. 151-155, 1992.
- [5] S. G. Chamberlain and J. P. Y. Lee, "A novel wide dynamic range silicon photodetector and linear imaging array," *IEEE Trans. Electron Devices.*, vol. ED-31, no.2, pp. 175-182, Feb. 1984.
- [6] R. Ginosar and Y. Y. Zeevi, "Adaptive sensitivity / intelligent scan imaging sensor chips," *SPIE*, vol. 1001, pp. 462-468, 1988.
- [7] K. Takada, et al., "Logarithmic-Converting CCD Line Sensor," *The J. of the institute of Television Engineers of Japan*, vol. 49, no. 2, pp. 169-175, 1995. [in Japanese].
- [8] K. Yamada, T. Nakano, and S. Yamamoto, "Wide Dynamic Range Vision Sensor for Autonomous Vehicles," *Proc. of IEEE Int. Conf. on Robotics and Automation*, pp. 770-775, 1995.